



Rapid **150** DeltaTech

Rapid 150 DeltaTech line – For demanding needs

Rapid 150 DeltaTech is the most dynamic product line within the 150-Series. With 7 different models and a wide range of standard options, each model can be tailor-made to each application. The following headlines are some highlights of the DeltaTech concept.

CleanGRIND Cutting technique

There are no shortcuts to the perfect regrind.

- Rapid has virtually perfected the art of processing high quality regrind. Consistent sized regrind with fewer fines that melts more uniformly. Recover your sprues without your production process and you'll feel the impact on the bottom line.

VersaGRIND Technology

- Specify the ideal granulator solution for your type and volume of plastic waste, granule size and recycling requirements. No compromises! Mix and match from Rapid's array of standardised options to create the granulator that exactly fits your application needs.

EasyCLEAN Engineering

- Easy cleaning and easy maintenance is fundamental demands for Rapid 150-Series. Instant access to all components provides easy cleaning when changing e.g. material or colours.

Cassette knife system

- No re-sharpening! No re-adjustments! Just remove the worn knives and replace them with new ones. The knife clearance between rotating- and stator knife will automatically be correct!
- Make sure that you easily and quickly can service your granulator for long lasting durability and top quality regrind.



For demanding needs

Standard hopper

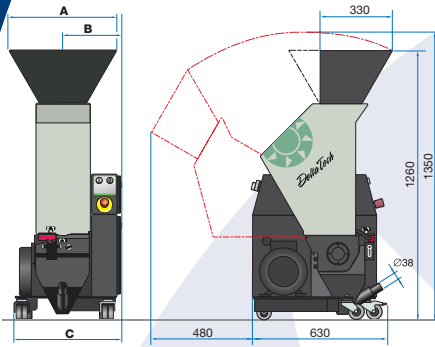

A	490	630	700
B	270	340	375
C	500	640	710

Hopper standard, base high-built

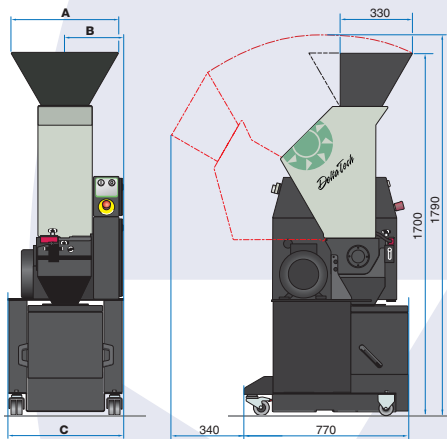

A	490	630	700
B	270	340	375
C	500	640	710

Docking model

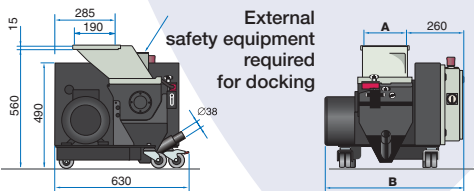

A	206	345
B	650	730

Mini model

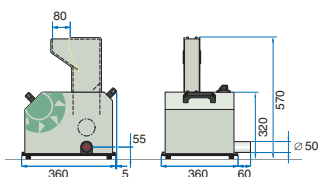

Rapid 150 DeltaTech

	150-07 Mini	150-21	150-35	150-42	150-21 Auger	150-21 Dock	150-35 Dock
CUTTER HOUSE							
Opening, mm	80x70	210x150	350x150	420x150	210x150	210x150	210x150
inches	3 1/8 x 2 3/4	8 1/4 x 6	13 3/4 x 6	16 1/2 x 6	3 1/8 x 6	8 1/4 x 6	13 3/4 x 6
Fixed knives, no	2	2	2	2	2	2	2
Hardened rotor end disc	-	◆	◆	◆	◆	◆	◆
Hardened cutter house	-	◇	◇	◇	◇	◇	◇
ROTOR							
Staggered design	-	◆	◆	◆	◆	◆	◆
Rotating knives	3x1	3x3	3x5	3x6	3x3	3x3	3x5
PowerTech knives	◇	◇	◇	◇	◇	◇	◇
Scissor cut knives	◆	◆	◆	◆	◆	◆	◆
Cassette knife system	◆	◆	◆	◆	◆	◆	◆
Twin bearing	◆	◆	◆	◆	◆	◆	◆
TRANSMISSION							
Motor 0,37 kW / 0,5 Hp	◆	-	-	-	-	-	-
Motor 2,2 kW / 3 Hp	-	◆	◆	◆	◆	◆	◆
Motor 4 kW / 5,5 Hp	-	◆	◆	◆	◆	◆	◆
Heavy duty transmission	◆	◆	◆	◆	◆	◆	◆
HOPPERS							
Top feed/high built	◆	◆	◆	◆	◇	◇	◇
Top feed/low built	-	◇	◇	◇	◇	◇	◇
Rear feed	◆	◇	◇	◇	◇	◇	◇
Removable flaps	-	◆	◆	◆	◆	◆	◆
BASE							
Standard	◆	◆	◆	◆	◆	◆	◆
High built	-	◇	◇	◇	◇	◇	◇
Low built	-	◇	◇	◇	◇	◇	◇
Low built electrical cabinet	-	◇	◇	◇	◇	◇	◇
SCREEN							
Hole diam., mm/inches	4 / 5/32"	5 / 3/16"	5 / 3/16"	5 / 3/16"	5 / 3/16"	5 / 3/16"	5 / 3/16"
Optional hole diam., mm	3, 5	3, 4, 6, 8			3, 4, 6, 8		
inches	1/8", 3/16"	1/8", 5/32", 1/4", 5/16"			1/8", 5/32", 1/4", 5/16"		
Reversible screen	◆	◆	◆	◆	◆	◆	◆
Hardened screen	-	◆	◆	◆	◆	◆	◆
Stitch reduced screen	-	◇	◇	◇	◇	◇	◇
Drop down screen cradle	◆	◆	◆	◆	◆	◆	◆
REGRIND COLLECTION BIN							
Dust sealed	◆	◆	◆	◆	◆	◆	◆
Diam 38 mm outlet	◆	◆	◆	◆	◆	◆	◆
Adapter for sack filling	-	◇	◇	◇	-	-	-
Granule container 45 l	◇	◇	◇	◇	◇	◇	◇
Air veyor system	◇	◇	◇	◇	◇	◇	◇
Level indicator capacitive type	-	◇	◇	◇	◇	◇	◇
SAFETY							
Interlocking guard	Fixed	◆	◆	◆	◆	◆	◆
PERFORMANCE							
Weight, kg	45	160	200	220	220	140	170
lbs	100	350	440	485	485	310	375
Throughput kg/h	<7	40	60	70	40	40	60
lbs/h	<15	90	130	150	90	90	130
Sound pressure level dB(A)	72-83 dB(A) depending on type of material, waste, feed rate, temperature, etc.						
OTHER OPTIONS							
Sound proof hood	◆	◇	◇	◇	◇	◇	◇
Hour counter	◇	◇	◇	◇	◇	◇	◇

◆ Standard, ◇ Optional, - not applicable

Auger model

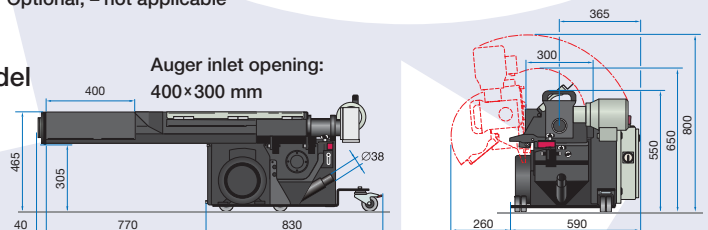

Rapid Granulator AB

Box 9, SE-330 10 Bredaryd, Sweden

Phone: +46 (0)370 86500 • Fax: +46 (0)370 80251

E-mail: info@rapidgranulator.se • www.rapidgranulator.se